

E-DRIVE

Gruppi con 1-2-3 pompe a velocità variabile e inverter di frequenza su ogni pompa
 Booster sets with 1-2-3 variable speed pumps and frequency inverter on each pump
 Grupos con 1-2-3 bombas de velocidad variable, convertidores de frecuencia en cada motor

Qmax 7,8 → 354 m³/h



Immagine indicativa con inverter tipo "V"
 Indicative image with "V" type inverter
 Imagen indicativa con inverter tipo "V"

SERIE E-DRIVE

Gruppi di sollevamento acqua progettati e realizzati per soddisfare le esigenze di pressione costante, economia di esercizio, minori consumi d'acqua, protezione contro la marcia a secco.

I vantaggi nell'utilizzo di questi gruppi sono: pressione costante, silenziosità di funzionamento, economia di esercizio, minori consumi d'acqua, protezione contro la marcia a secco. Tutti i gruppi sono forniti già predisposti per l'utilizzo con serbatoi a membrana, l'uso ne è raccomandato.

La logica di funzionamento automatica master-slave degli inverter di frequenza permette il mantenimento del corretto pari utilizzo delle pompe. L'intero sistema funziona anche con una o più pompe disattivate, in blocco o in avaria, provvedendo alla gestione ed inviando il segnale di allarme.

Tutte le impostazioni del sistema e le letture degli stati di gestione ed allarmi, avvengono tramite il display retroilluminati.

E-DRIVE SERIES

Booster sets designed and built to ensure a constant pressure, specifically suitable for domestic applications and small or medium systems for civil, agricultural or industrial uses.

Booster sets strengths and benefit: constant pressure, low noise operation, low running costs, low water consumption, protection against dry running, is recommended to use the sets with membrane pressure tanks.

The master-slave automatic operation logic of the frequency inverters allows the equal use of the pumps. The entire system also works with one or more pumps deactivated, either in block or in failure, providing for the management and sending the alarm signal.

All system settings and management status and alarm readings are made via display.

SERIE E-DRIVE

Grupos de bombeo de agua diseñadas y fabricadas para satisfacer las necesidades de presión constante, perfectas para instalaciones domésticas, pequeñas y medianas instalaciones civiles, agrícolas o industriales.

Las ventajas en el uso de estos grupos son: presión constante, funcionamiento silencioso, economía de uso, menor consumo de agua, protección contra el funcionamiento en seco.

Todos los grupos se suministran ya preparados con la conexión para el uso de tanques de membrana, se recomienda su uso.

La lógica de operación automática master-slave de los convertidores de frecuencia permite el consumo igual entre las bombas. Todo el sistema también funciona con una o más bombas desactivadas, ya sea en bloque o en falla, proporcionando la gestión y el envío de la señal de alarma.

Todos los ajustes del sistema y el estado de gestión y las lecturas de alarma se realizan a través de la pantalla.



residenziale
 residential / residencial



industriale
 industrial / industrial



agricolo
 agricultural / agrícola

CARATTERISTICHE

- 1-2-3 elettropompe a seconda del modello del gruppo (tenuta meccanica, Hz 50)
- Base e porta quadro elettrico in lamiera verniciata (solo nei gruppi a più pompe, senza base per pompa singola)
- Collettori di aspirazione e di mandata in acciaio zincato (solo per gruppi con 2 o più pompe)
- Valvole a sfera con bocchettone in aspirazione ed in mandata di ciascuna pompa (solo per gruppi con 2 o più pompe, la pompa singola viene fornita senza valvole di intercettazione)
- Valvola di ritegno in mandata di ciascuna pompa
- 1 sensore di pressione elettronico per ogni pompa installata
- Predisposizione all'utilizzo di serbatoio a membrana

CARATTERISTICHE ELETTRICHE

- 1 modulo inverter montato su ciascuna pompa
- Centralino elettrico di protezione gruppo, contenente interruttore magnetotermico di protezione (per pompe singole fornito non cablato)

ALCUNI PARAMETRI IMPOSTABILI

- Pressione di uscita
- Rotazione automatica
- Arresto marcia a secco
- Logica funzionamento master-slave
- Avvio pompe in cascata
- Corrente massima

ALCUNI PARAMETRI VISUALIZZABILI

- Ore funzionamento pompa
- Numero avviamenti
- Errori

ALCUNI ALLARMI VISUALIZZABILI

- Avaria pompa
- Basso livello acqua
- Guasto

FEATURES

- 1-2-3 electric pumps depending from the model of booster set (mechanical seal, Hz 50)
- Base in painted steel (only for booster sets with more than one pump, for single pump skid is not included)
- Suction and delivery galvanized steel manifolds, (only for booster sets with 2 or more pumps)
- Ball valves with union on suction and discharge of each pump (only for booster sets with 2 or more pumps, the single pump is supplied without on-off valves)
- Check valve in to delivery of each pump
- 1 electronic pressure transducer for each pump installed
- Sets supplied with membrane pressure tank connections

ELECTRICAL FEATURES

- 1 inverter module installed for each pump
- Electric protection control panel containing thermal magnetic (for pump only supply not connected)

SOME SETTABLE PARAMETERS

- Outlet pressure
- Automatic rotation
- Dry running stop
- Master-slave operation logic
- Starting pumps in cascade
- Maximum current

SOME DISPLAYABLE PARAMETERS

- Pump operating hours
- Number of pump starts
- Errors

SOME ALARMS THAT CAN BE DISPLAYED

- Pump failure
- Low water level
- Failure

CARACTERÍSTICAS

- 1-2-3 bombas eléctricas según el modelo de la unidad (cierre mecánico, Hz 50)
- Base de hierro pintada solo en grupos de bombas múltiples, sin base para bomba única
- Colectores de aspiración e impulsión en acero galvanizado, (solo para grupos con 2 o más bombas)
- Válvulas e cierre en los lados de aspiración e impulsión de cada bomba (solo para grupos con 2 o más bombas, la bomba individual se suministra sin válvulas de cierre)
- Válvulas de retención en el lado de entrega de cada bomba
- 1 sensor de presión electrónico para cada bomba instalada
- Conexión para el uso de tanques de membrana

CARACTERÍSTICAS ELÉCTRICAS

- 1 módulo inversor montado en el motor eléctrico de cada bomba
- Unidad eléctrica para proteger la unidad, que contiene un interruptor de protección magnetotérmica (para bombas individuales es suministrada sin cableado)

ALGUNOS PARÁMETROS CONFIGURABLES

- Presión de salida
- Rotación automática
- Parada para marcha en seco
- Lógica de operación master-slave
- Arranque de bombas en cascada
- Corriente máxima

ALGUNOS PARÁMETROS VISUALIZABLES

- Horas de funcionamiento de la bomba
- Número de arranques de bomba
- Erroros

ALGUNAS ALARMAS QUE SE PUEDEN MOSTRAR

- Falla de la bomba
- Bajo nivel de agua
- Avería

MODULO INVERTER / INVERTER MODULE / MÓDULO INVERSOR

INVERTER DI FREQUENZA
INSTALLATO SU OGNI POMPA

Il modulo inverter è un dispositivo installato sulla pompa che include un sensore di pressione ed un convertitore di frequenza elettronico (inverter).

Applicato sulla elettropompa regola la sua velocità in modo da ottenere pressione costante al variare della portata d'acqua richiesta.

FREQUENCY INVERTER
INSTALLED ON EVERY PUMP

The inverter module is a device installed on the pump, that includes a electronic pressure transducer and an electronic inverter.

Installed on the outlet discharger line of each electronic pump, it controls the pump's speed rotation which is connected and maintain a fixed pressure at the setted flow rate variance.

CONVERTIDOR DE FRECUENCIA
INSTALADO EN CADA BOMBA

El módulo convertidor de frecuencia es un dispositivo instalado en el motor de la bomba, que incluye un sensor de presión y un convertidor electrónico de frecuencia (inversor).

Aplicado en el motor de la bomba eléctrica, regula su velocidad para obtener una presión constante cuando se cambia el caudal de agua requerido.



Modulo inverter tipo "C"
Type "C" inverter module
Módulo inersor tipo "C"

Inverter installato frontale, sulla morsettiere del motore
Front installed inverter, on the motor terminal board
Inversor instalado frontalmente, en la caja de terminales del motor



Modulo inverter tipo "V"
Type "V" inverter module
Módulo inersor tipo "V"

Inverter installato sul lato ventola del motore
Inverter installed on the fan side of the motor
Inversor instalado en el lado del ventilador del motor



FUNZIONAMENTO

All'abbassamento di pressione nell'impianto dovuto a prelievo d'acqua, una pompa si mette in funzione per soddisfare la portata d'acqua richiesta; l'avviamento della seconda e terza pompa (se presenti) avviene in cascata, quando la prima pompa raggiunge la massima velocità di rotazione. La pressione pompe è regolabile dall'utente tramite tasti posti sull'inverter.

Nelle applicazioni con inverter in parallelo (gruppi con due o tre pompe) ciascun inverter controlla e protegge la pompa alla quale è connesso, mentre il lavoro è distribuito tra le diverse pompe del gruppo sulla base delle effettive ore di lavoro di ciascuna pompa. In caso di guasto di un'unità del gruppo, le rimanenti pompe continuano a funzionare.

FUNCTIONING

In case of pressure drop in/reduction, caused by water withdrawal, the first pump start to satisfy at the requested flow rate. When the first pump reaches the maximum rotation speed the others pump (if present and necessary) start in cascading. The pump pressure can be setted by the user with switches button on the inverter (normally all pumps are setted at the same pressure level).

In parallel inverter installations (booster sets with two or three pumps), each inverter controls and protects it's pump and the operation is shared among all the connected pumps to average out pump wear. In case of failure, the remaining pumps will maintain the pumping operation.

FUNCIONAMIENTO

Cuando la presión en el sistema disminuye debido a la demanda de agua, se arranca una bomba para satisfacer el flujo de agua requerido; el arranque de la segunda y tercera bomba (si están presentes) ocurre en cascada, cuando la primera bomba alcanza la velocidad máxima de rotación. El usuario puede ajustar la presión de la bomba con los botones del inersor.

En aplicaciones con inversores en paralelo (grupos con dos o tres bombas) cada inersor controla y protege la bomba a la que está conectado, mientras que el trabajo se distribuye entre las diferentes bombas del grupo en función de las horas de trabajo reales de cada bomba. En caso de falla de una bomba del grupo, las bombas restantes continúan funcionando.



VANTAGGI

- Protegge il motore da sovraccarichi
- Protegge il motore dalla marcia a secco,
- Attua la partenza e l'arresto dolci (soft-start e soft-stop) per aumentare la vita del sistema e ridurre i picchi di assorbimento
- Fornisce un'indicazione della corrente assorbita e della tensione di alimentazione
- Registra le ore di funzionamento e, in funzione di queste, eventuali allarmi
- Si connette agli altri inverter per realizzare il funzionamento combinato
- Legge le ore di lavoro di ciascuna pompa

VISUALIZZAZIONI

Il display a cristalli liquidi retroilluminato agevola l'utilizzo anche in assenza di luce.



ALLARMI E PROTEZIONI

Allarme di marcia a secco mediante lettura del fattore di potenza (cosφ)

Quando la pompa lavora a secco, il valore del fattore di potenza (cosφ) scende al di sotto di un valore critico impostabile e l'inverter provvede ad arrestarla. L'inverter esegue successivamente diversi tentativi di riavvio (dopo 10,20,40,80,160 minuti) alla conclusione dei quali, se l'allarme di mancanza acqua non è rientrato, la pompa viene arrestata definitivamente.

In condizioni di funzionamento controllato da inverter, ed utilizzando serbatoi a membrana, è sufficiente un volume totale del serbatoio, espresso in litri, non inferiore al 10% della portata massima della singola pompa espressa in litri/min.



MOTORI DELLE POMPE

I gruppi che riportano nel modello la "...M..." montano inverter con ingresso monofase (1~230V) ed uscita trifase (3~230V), la pompa collegata dunque è trifase.

I gruppi che riportano nel modello la "...T..." montano inverter con ingresso trifase (3~400V) ed uscita trifase (3~400V), la pompa collegata dunque è trifase.

BENEFITS

- Motor protection against overload
- Motor protection against dry running
- Integrated soft-start and soft-stop functions, extending the life of the system and reducing peak absorption
- Indication of input current and supply voltage
- Recording running hours and loggins errors and alarms reported by the system
- Connect to other inverters to get combined operation
- Reads the working hours of each pump

DISPLAY VIEWS

The liquid cristal illuminated display ensures is easy to operate.

ALARMS & PROTECTIONS

Dry running signal via cosφ value

If pump runs dry, its cosφ value drops below a settable cosφ value, and the inverter stops the pump after 2 seconds. Inverter will try to start the pump every 10,20,40,80 and 160 minutes, after which it will declare an alarm and stop the pump if the condition persists.

In case of use under inverter and with membrane tanks, is necessary a total volume of the tank (expressed in liters) not lower than the 10% of the maximum single pump flow rate.

PUMP'S MOTORS

The booster sets with the "...M..." in the model are equipped with single phase inverter input (1~230V) and three-phase output (3~230V), a three phase pumps is connected.

The booster sets with the "...T..." in the model are equipped with three-phase inverter input (3~400V) and three-phase output (3~400V), a three-phase pumps is connected.

BENEFICIOS

- Protege el motor de sobrecargas
- Protege el motor del funcionamiento en seco
- Activa el arranque y la parada suaves (soft-start y soft-stop) para aumentar la vida útil del sistema y reducir los picos de absorción
- Proporciona una indicación de la corriente absorbida y la tensión de alimentación
- Registra las horas de funcionamiento y cualquier alarma
- Se conecta a los otros inversores para realizar la operación combinada
- Lee las horas de trabajo de cada bomba

VISTAS DE PANTALLA

La pantalla retroiluminada de cristal líquido facilita su uso incluso en ausencia de luz.

ALARMAS Y PROTECCIONES

Alarma de funcionamiento en seco leyendo el factor de potencia (cosφ)

Cuando la bomba funciona en seco, el valor del factor de potencia (cosφ) cae por debajo de un valor crítico configurable y el inersor para la bomba. Luego, el inersor realiza varios intentos de arranque (después de 10, 20, 40, 80, 160 minutos) al final de los cuales, si la alarma de falta de agua no ha regresado, la bomba se detiene definitivamente.

En condiciones de operación controladas por el inersor, y usando tanques de membrana, es suficiente un volumen total del tanque, expresado en litros, de no menos del 10% del caudal máximo de la bomba individual expresado en litros/min.

MOTORES DE LAS BOMBAS

Los grupos que llevan en el modelo la "...M..." montan inversores con entrada monofásica (1~230V) y salida trifásica (3~230V), por lo tanto la bomba conectada es trifásica.

Los grupos que llevan en el modelo la "...T..." montan inversores con entrada trifásica (3~400V) y salida trifásica (3~400V), por lo tanto la bomba conectada es trifásica.

E-DRIVE

1 pompa centrifuga multistadio a velocità variabile - pressione costante
 1 pump multistage centrifugal with variable speed - constant pressure
 1 bomba centrifuga multicelular con velocidad variable - presión constante

7,8 m³/h	+40° 0° °C	°C	50 h
-------------	------------------	----	---------



Immagine indicativa con inverter tipo "C"
 Indicative image with "C" type inverter
 Imagen indicativa con inverter tipo "C"



1 Gruppo con n.1 pompa orizzontale
 Booster set with n.1 horizontal pump
 Grupo con n.1 bomba horizontal

MODELLO / MODEL	PORTATA TOTALE / TOTAL FLOW RATE							
	l/m	10	30	50	70	90	110	130
	m³/h	0,6	1,8	3	4,2	5,4	6,6	7,8
PREVALENZA TOTALE (mt) / TOTAL HEAD (mt)								
E-DRIVE-1PHM-P-C01	40	34,5	27*	17				
E-DRIVE-1PHM-P-C02	52	44,5	34*	22,5				
E-DRIVE-1PHM-F-C03	55	50	42	31*	16			
E-DRIVE-1PHM-F-C04	67	63	53	40*	21			
E-DRIVE-1PHM-F-C05	78	74	61	45*	24			
E-DRIVE-1PHM-F-C06	90	84	71	54*	30			
E-DRIVE-1PHM-F-C07	101	94	79	58*	33			
E-DRIVE-1PHM-P-C08	35	34,5	31	26	20*	13,5	5	
E-DRIVE-1PHM-P-C09	50	47	42	37	30,5*	22	11	5
E-DRIVE-1PHM-F-C10	57	55	52	48	42	34*	25	20
E-DRIVE-1PHM-F-C11	70	66	63	58	52	43*	31	24
E-DRIVE-1PHM-F-C12	81	77	73	66	58	48*	35	27
E-DRIVE-1PHM-F-C13	92	87	82	75	66	54*	38	28
E-DRIVE-1PHM-F-C14	104	98	93	86	76	64*	45	34

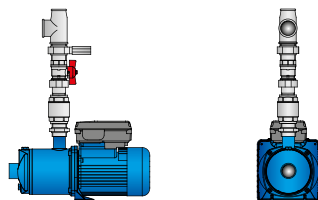
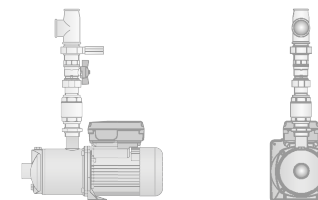
ALIMENTAZIONE / POWER SUPPLY	materiali materials	tipo inverter inverter type	POTENZA / POWER		L W H			DN in	DN out	kg
1x230 V~ (50 Hz)			kW	Hp	mm	mm	mm			
E-DRIVE-1PHM-P-C01	●●	C	0,45	0,6	540	181	485	1"	1"	15
E-DRIVE-1PHM-P-C02	●●	C	0,55	0,75	565	181	485	1"	1"	16
E-DRIVE-1PHM-F-C03	●●	C	0,75	1	640	181	510	1" ¼	1"	18
E-DRIVE-1PHM-F-C04	●●	C	0,9	1,2	665	181	510	1" ¼	1"	20
E-DRIVE-1PHM-F-C05	●●	C	1,1	1,5	690	181	510	1" ¼	1"	20
E-DRIVE-1PHM-F-C06	●●	C	1,3	1,8	750	181	510	1" ¼	1"	24
E-DRIVE-1PHM-F-C07	●●	C	1,5	2	775	181	510	1" ¼	1"	25
E-DRIVE-1PHM-P-C08	●●	C	0,55	0,75	540	181	485	1"	1"	16
E-DRIVE-1PHM-P-C09	●●	C	0,75	1	590	181	485	1"	1"	20
E-DRIVE-1PHM-F-C10	●●	C	1,1	1,5	640	181	510	1" ¼	1"	19
E-DRIVE-1PHM-F-C11	●●	C	1,3	1,8	700	181	510	1" ¼	1"	23
E-DRIVE-1PHM-F-C12	●●	C	1,5	2	730	181	510	1" ¼	1"	23
E-DRIVE-1PHM-F-C13	●●	C	2,2	3	800	181	510	1" ¼	1"	29
E-DRIVE-1PHM-F-C14	●●	C	2,2	3	820	181	510	1" ¼	1"	30

E-DRIVE

1 pompa centrifuga multistadio a velocità variabile - pressione costante
 1 multistage centrifugal pump with variable speed - constant pressure
 1 bomba centrifuga multicelular con velocidad variable - presión constante

14
m³/h

+90°
0°
°C

°C

50
h



Immagine indicativa con inverter tipo "C"
 Indicative image with "C" type inverter
 Imagen indicativa con inverter tipo "C"



1 Gruppo con n.1 pompa verticale
 Booster set with n.1 vertical pump
 Grupo con n.1 bomba vertical

MODELLO / MODEL		PORTATA TOTALE / TOTAL FLOW RATE													
		l/m	16,6	25	33,3	41,6	50	66,6	75	91,6	116,6	150	183,3	233,3	
		m³/h	0	1	1,5	2	2,5	3	4	4,5	5,5	7	9	11	14
		PREVALENZA TOTALE (mt) / TOTAL HEAD (m)													
E-DRIVE-1PVM-F-C01	E-DRIVE-1PVT-F-C01	48	41,5	36,5	30*	22									
E-DRIVE-1PVM-F-C02	E-DRIVE-1PVT-F-C02	74,5	64	56,5	46,5*	34									
E-DRIVE-1PVM-F-C03	E-DRIVE-1PVT-F-C03	102,5	88	78	64*	47									
E-DRIVE-1PVM-F-C04	E-DRIVE-1PVT-F-C04	150,5	130	115	95*	69,5									
E-DRIVE-1PVM-F-C05	E-DRIVE-1PVT-F-C05	54,5	48	44	40,5	36*	26,5	21							
E-DRIVE-1PVM-F-C06	E-DRIVE-1PVT-F-C06	66,5	59	55	50,5	45,5*	34	27							
E-DRIVE-1PVM-F-C07	E-DRIVE-1PVT-F-C07	77	68	63	58	52*	38,5	30,5							
E-DRIVE-1PVM-F-C08	E-DRIVE-1PVT-F-C08	89	78,5	73	67	60*	44,5	36							
E-DRIVE-1PVM-F-C09	E-DRIVE-1PVT-F-C09	99,5	87,5	81	74	66*	48,5	38,5							
E-DRIVE-1PVM-F-C10	E-DRIVE-1PVT-F-C10	112,5	83	99,5	92,5	83*	58	41,5							
E-DRIVE-1PVM-F-C11	E-DRIVE-1PVT-F-C11	127	118	111,5	103,5	93*	64	45,5							
E-DRIVE-1PVM-F-C12	E-DRIVE-1PVT-F-C12	144	134,5	128	119	107,5*	76	55,5							
E-DRIVE-1PVM-F-C13	E-DRIVE-1PVT-F-C13	158,5	148	140,5	130,5	118*	83	60							
E-DRIVE-1PVM-F-C14	E-DRIVE-1PVT-F-C14	68,5			61,5	59,5	55	52	46*	32,5					
E-DRIVE-1PVM-F-C15	E-DRIVE-1PVT-F-C15	79,5			70,5	68	62,5	59	51,5*	35,5					
E-DRIVE-1PVM-F-C16	E-DRIVE-1PVT-F-C16	92			84	81,5	76	72,5	64,5*	47					
E-DRIVE-1PVM-F-C17	E-DRIVE-1PVT-F-C17	103			94	91	85	81	72*	66					
E-DRIVE-1PVM-F-C18	E-DRIVE-1PVT-F-C18	113			105,5	102	93,5	89	80,5*	59,5					
E-DRIVE-1PVM-F-C19	E-DRIVE-1PVT-F-C19	127,5			118,5	114,5	105	99,5	90*	66					
E-DRIVE-1PVM-F-C20	E-DRIVE-1PVT-F-C20	142			131,5	126,5	115,5	110	99*	72					
-	E-DRIVE-1PVT-F-C21	159			149,5	144,5	133	127	115*	85,5					
E-DRIVE-1PVM-F-C22	E-DRIVE-1PVT-F-C22	47			43,5	42,5	41,5	39	35,5*	29	14,5				
E-DRIVE-1PVM-F-C23	E-DRIVE-1PVT-F-C23	59,5			56	55	53,5	51	46,5*	39	21				
E-DRIVE-1PVM-F-C24	E-DRIVE-1PVT-F-C24	71			66	65	63	60	54,5*	44,5	23,5				
-	E-DRIVE-1PVT-F-C25	82,5			76	75	72,5	68,5	62*	50	25				
-	E-DRIVE-1PVT-F-C26	91,5			89,5	88,5	86	81,5	74*	64	42				
-	E-DRIVE-1PVT-F-C27	113			111	109,5	107	101,5	92,5*	80,5	53,5				
-	E-DRIVE-1PVT-F-C28	133			130	128,5	125,5	118,5	108*	93,5	61,5				
-	E-DRIVE-1PVT-F-C29	153,5			150,5	149	145,5	138	125,5*	109	61,5				

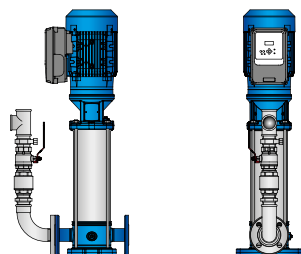
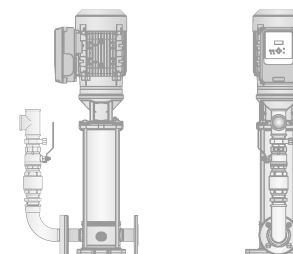
ALIMENTAZIONE / POWER SUPPLY		materiali materials	tipo inverter inverter type	POTENZA / POWER			L mm	W mm	H mm	DN in	DN out	kg
1x230 V~ (50 Hz)	3x400 V~ (50 Hz)			kW	Hp	W						
E-DRIVE-1PVM-F-C01	E-DRIVE-1PVT-F-C01	●●	C	0,37	0,5	450	220	892	1"	1"	35	
E-DRIVE-1PVM-F-C02	E-DRIVE-1PVT-F-C02	●●	C	0,55	0,75	450	220	982	1"	1"	38	
E-DRIVE-1PVM-F-C03	E-DRIVE-1PVT-F-C03	●●	C	0,75	1	450	220	1088	1"	1"	42	
E-DRIVE-1PVM-F-C04	E-DRIVE-1PVT-F-C04	●●	C	1,1	1,5	450	220	1245	1"	1"	48	
E-DRIVE-1PVM-F-C05	E-DRIVE-1PVT-F-C05	●●	C	0,75	1	420	220	764	1" 1/4	1" 1/4	37	
E-DRIVE-1PVM-F-C06	E-DRIVE-1PVT-F-C06	●●	C	1,1	1,5	420	220	788	1" 1/4	1" 1/4	38	
E-DRIVE-1PVM-F-C07	E-DRIVE-1PVT-F-C07	●●	C	1,1	1,5	420	220	812	1" 1/4	1" 1/4	39	
E-DRIVE-1PVM-F-C08	E-DRIVE-1PVT-F-C08	●●	C	1,5	2	420	220	878	1" 1/4	1" 1/4	43	
E-DRIVE-1PVM-F-C09	E-DRIVE-1PVT-F-C09	●●	C	1,5	2	420	220	902	1" 1/4	1" 1/4	43	
E-DRIVE-1PVM-F-C10	E-DRIVE-1PVT-F-C10	●●	C	1,5	2	450	220	1133	1"	1"	48	
E-DRIVE-1PVM-F-C11	E-DRIVE-1PVT-F-C11	●●	C	1,5	2	450	220	1178	1"	1"	48	
E-DRIVE-1PVM-F-C12	E-DRIVE-1PVT-F-C12	●●	C	2,2	3	450	220	1223	1"	1"	51	
E-DRIVE-1PVM-F-C13	E-DRIVE-1PVT-F-C13	●●	C	2,2	3	450	220	1268	1"	1"	52	
E-DRIVE-1PVM-F-C14	E-DRIVE-1PVT-F-C14	●●	C	1,5	2	420	220	830	1" 1/4	1" 1/4	41	
E-DRIVE-1PVM-F-C15	E-DRIVE-1PVT-F-C15	●●	C	1,5	2	420	220	854	1" 1/4	1" 1/4	42	
E-DRIVE-1PVM-F-C16	E-DRIVE-1PVT-F-C16	●●	C	2,2	3	420	220	917	1" 1/4	1" 1/4	46	
E-DRIVE-1PVM-F-C17	E-DRIVE-1PVT-F-C17	●●	C	2,2	3	420	220	941	1" 1/4	1" 1/4	49	
E-DRIVE-1PVM-F-C18	E-DRIVE-1PVT-F-C18	●●	C	2,2	3	460	240	1185	1" 1/4	1" 1/4	51	
E-DRIVE-1PVM-F-C19	E-DRIVE-1PVT-F-C19	●●	C	2,2	3	460	240	1237	1" 1/4	1" 1/4	52	
E-DRIVE-1PVM-F-C20	E-DRIVE-1PVT-F-C20	●●	C	2,2	3	460	240	1289	1" 1/4	1" 1/4	53	
-	E-DRIVE-1PVT-F-C21	●●	C	3	4	460	240	1390	1" 1/4	1" 1/4	61	
E-DRIVE-1PVM-F-C22	E-DRIVE-1PVT-F-C22	●●	C	1,5	2	420	270	836	1" 1/2	1" 1/2	44	
E-DRIVE-1PVM-F-C23	E-DRIVE-1PVT-F-C23	●●	C	2,2	3	420	270	905	1" 1/2	1" 1/2	50	
E-DRIVE-1PVM-F-C24	E-DRIVE-1PVT-F-C24	●●	C	2,2	3	420	270	935	1" 1/2	1" 1/2	51	
-	E-DRIVE-1PVT-F-C25	●●	C	3	4	420	270	1003	1" 1/2	1" 1/2	55	
-	E-DRIVE-1PVT-F-C26	●●	C	3	4	470	260	1127	1" 1/2	1" 1/2	57	
-	E-DRIVE-1PVT-F-C27	●●	C	4	5,5	470	260	1187	1" 1/2	1" 1/2	62	
-	E-DRIVE-1PVT-F-C28	●●	C	4	5,5	470	260	1247	1" 1/2	1" 1/2	63	
-	E-DRIVE-1PVT-F-C29	●●	C	5,5	7,5	470	260	1504	1" 1/2	1" 1/2	92	

E-DRIVE

2 pompe centrifughe multistadio a velocità variabile - pressione costante
 2 multistage centrifugal pumps with variable speed - constant pressure
 2 bombas centrifugas multicelulares con velocidad variable - presión constante

58
m³/h

+40°
0°
°C

°C

50
h



Immagine indicativa con inverter tipo "C"
 Indicative image with "C" type inverter
 Imagen indicativa con inductor tipo "C"



2 Gruppo con n.2 pompe orizzontali
 Booster set with n.2 horizontal pumps
 Grupo con n.2 bombas horizontales

MODELLO / MODEL	PORTATA TOTALE / TOTAL FLOW RATE																				
	l/m	0	40	80	120	160	200	240	260	300	340	380	420	460	600	667	734	834	934	967	
	m³/h	0	2,4	4,8	7,2	9,6	12	14,4	15,6	18	20,4	22,8	25,2	27,6	36	40	44	50	56	58	
	PREVALENZA TOTALE (mt) / TOTAL HEAD (mt)																				
E-DRIVE-2PHM-P-C01	E-DRIVE-2PHT-P-C01	40	34,5	27*	17																
E-DRIVE-2PHM-P-C02	E-DRIVE-2PHT-P-C02	52	44,5	34*	22,5																
E-DRIVE-2PHM-F-C03	E-DRIVE-2PHT-F-C03	55	50	42	31*	16															
E-DRIVE-2PHM-F-C04	E-DRIVE-2PHT-F-C04	67	63	53	40*	21															
E-DRIVE-2PHM-F-C05	E-DRIVE-2PHT-F-C05	78	74	61	45*	24															
E-DRIVE-2PHM-F-C06	E-DRIVE-2PHT-F-C06	90	84	71	54*	30															
E-DRIVE-2PHM-F-C07	E-DRIVE-2PHT-F-C07	101	94	79	58*	33															
E-DRIVE-2PHM-P-C08	E-DRIVE-2PHT-P-C08	35	34,5	31	26	20*	13,5	5													
E-DRIVE-2PHM-P-C09	E-DRIVE-2PHT-P-C09	50	47	42	37	30,5*	22	11	5												
E-DRIVE-2PHM-F-C10	E-DRIVE-2PHT-F-C10	57	55	52	48	42	34*	25	20												
E-DRIVE-2PHM-F-C11	E-DRIVE-2PHT-F-C11	70	66	63	58	52	43*	31	24												
E-DRIVE-2PHM-F-C12	E-DRIVE-2PHT-F-C12	81	77	73	66	58	48*	35	27												
E-DRIVE-2PHM-F-C13	E-DRIVE-2PHT-F-C13	92	87	82	75	66	54*	38	28												
-	E-DRIVE-2PHT-F-C14	104	98	93	86	76	64*	45	34												
E-DRIVE-2PHM-F-C15	E-DRIVE-2PHT-F-C15	35			32	31	30	28	27	25,5	23*	19,5	16	11							
E-DRIVE-2PHM-F-C16	E-DRIVE-2PHT-F-C16	48			44	42	40,5	38,5	37	35	31*	26	23	15							
-	E-DRIVE-2PHT-F-C17	59			54	52	50,5	48	46	43	39*	34	27	20							
-	E-DRIVE-2PHT-F-C18	71			65	62	59,5	56	54	51	45*	39	31	22							
-	E-DRIVE-2PHT-F-C19	84			77	74	72	69	67	64	59,5*	53	40	29							
-	E-DRIVE-2PHT-F-C20	96			89	84	82	78	76	72,5	67*	60	50	32							
-	E-DRIVE-2PHT-F-C21	29							26	25,5	25,5	25	24	23	19*	17,5	14,5	9,5			
-	E-DRIVE-2PHT-F-C22	44							39,5	39	38	37,5	36	34,5	29,5*	26	22	14,5			
-	E-DRIVE-2PHT-F-C23	58,5							53	52	51,5	50,5	49	47	40*	35,5	30	20			
-	E-DRIVE-2PHT-F-C24	73							65,5	64,5	63,5	62,5	60	57,5	49*	43,5	36,5	24			
-	E-DRIVE-2PHT-F-C25	87,5							79,5	78	77	75,5	73	71	61,5*	54	46	31,5			
-	E-DRIVE-2PHT-F-C26	102							92	90,5	89	87,5	85	82	70,5*	62	52,5	36			
-	E-DRIVE-2PHT-F-C27	31										27,5	27	26,5	26	24	22,5	20,5*	16,5	12	10
-	E-DRIVE-2PHT-F-C28	46,5										41,5	41	40	39,5	36,5	34,5	31,5*	25,5	19	16
-	E-DRIVE-2PHT-F-C29	62,5										56	55,5	54	53,5	49,5	46,5	42,5*	34,5	26	22
-	E-DRIVE-2PHT-F-C30	78,5										70,5	69,5	68	67	62	58,5	53,5*	43,5	32,5	28

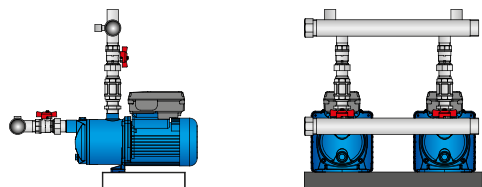
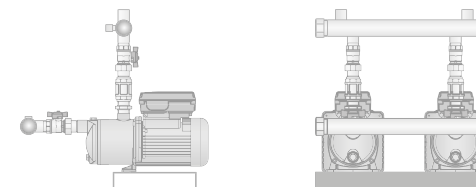
ALIMENTAZIONE / POWER SUPPLY		materiali materials	tipo inverter inverter type	POTENZA / POWER		L mm	W mm	H mm	DN in	DN out	kg
1x230 V~ (50 Hz)	3x400 V~ (50 Hz)			kW	Hp						
E-DRIVE-2PHM-P-C01	E-DRIVE-2PHT-P-C01	●●●	C	2x0,45	2x0,6	900	520	660	1" ½	1" ½	56
E-DRIVE-2PHM-P-C02	E-DRIVE-2PHT-P-C02	●●●	C	2x0,55	2x0,75	900	520	660	1" ½	1" ½	56
E-DRIVE-2PHM-F-C03	E-DRIVE-2PHT-F-C03	●●●	C	2x0,75	2x1	980	560	660	2"	1" ½	58
E-DRIVE-2PHM-F-C04	E-DRIVE-2PHT-F-C04	●●●	C	2x1,1	2x1,5	1000	560	660	2"	1" ½	61
E-DRIVE-2PHM-F-C05	E-DRIVE-2PHT-F-C05	●●●	C	2x1,1	2x1,5	1020	560	660	2"	1" ½	63
E-DRIVE-2PHM-F-C06	E-DRIVE-2PHT-F-C06	●●●	C	2x1,5	2x2	1045	560	660	2"	1" ½	68
E-DRIVE-2PHM-F-C07	E-DRIVE-2PHT-F-C07	●●●	C	2x1,5	2x2	1070	560	660	2"	1" ½	71
E-DRIVE-2PHM-P-C08	E-DRIVE-2PHT-P-C08	●●●	C	2x0,55	2x0,75	900	520	660	1" ½	1" ½	56
E-DRIVE-2PHM-P-C09	E-DRIVE-2PHT-P-C09	●●●	C	2x0,75	2x1	900	520	660	1" ½	1" ½	61
E-DRIVE-2PHM-F-C10	E-DRIVE-2PHT-F-C10	●●●	C	2x1,1	2x1,5	980	560	660	2"	1" ½	61
E-DRIVE-2PHM-F-C11	E-DRIVE-2PHT-F-C11	●●●	C	2x1,5	2x2	1000	560	660	2"	1" ½	68
E-DRIVE-2PHM-F-C12	E-DRIVE-2PHT-F-C12	●●●	C	2x1,5	2x2	1020	560	660	2"	1" ½	69
E-DRIVE-2PHM-F-C13	E-DRIVE-2PHT-F-C13	●●●	C	2x2,2	2x3	1045	560	660	2"	1" ½	70
-	E-DRIVE-2PHT-F-C14	●●●	C	2x2,2	2x3	1070	560	660	2"	1" ½	71
E-DRIVE-2PHM-F-C15	E-DRIVE-2PHT-F-C15	●●●	C	2x1,1	2x1,5	1010	560	660	2" ½	2"	61
E-DRIVE-2PHM-F-C16	E-DRIVE-2PHT-F-C16	●●●	C	2x1,5	2x2	1040	560	660	2" ½	2"	68
-	E-DRIVE-2PHT-F-C17	●●●	C	2x2,2	2x3	1070	560	660	2" ½	2"	70
-	E-DRIVE-2PHT-F-C18	●●●	C	2x2,2	2x3	1100	560	660	2" ½	2"	71
-	E-DRIVE-2PHT-F-C19	●●●	C	2x3	2x4	1065	560	660	2" ½	2"	88
-	E-DRIVE-2PHT-F-C20	●●●	C	2x3	2x4	1095	560	660	2" ½	2"	88
-	E-DRIVE-2PHT-F-C21	●●●	C	2x1,5	2x2	1090	700	720	3"	2" ½	89
-	E-DRIVE-2PHT-F-C22	●●●	C	2x2,2	2x3	1090	700	720	3"	2" ½	101
-	E-DRIVE-2PHT-F-C23	●●●	C	2x3	2x4	1140	700	720	3"	2" ½	106
-	E-DRIVE-2PHT-F-C24	●●●	C	2x4	2x5,5	1260	700	720	3"	2" ½	136
-	E-DRIVE-2PHT-F-C25	●●●	C	2x5,5	2x7,5	1260	700	720	3"	2" ½	156
-	E-DRIVE-2PHT-F-C26	●●●	C	2x5,5	2x7,5	1260	700	720	3"	2" ½	156
-	E-DRIVE-2PHT-F-C27	●●●	C	2x2,2	2x3	1090	700	720	3"	2" ½	101
-	E-DRIVE-2PHT-F-C28	●●●	C	2x3	2x4	1090	700	720	3"	2" ½	107
-	E-DRIVE-2PHT-F-C29	●●●	C	2x4	2x5,5	1260	700	720	3"	2" ½	131
-	E-DRIVE-2PHT-F-C30	●●●	C	2x5,5	2x7,5	1260	700	720	3"	2" ½	156

E-DRIVE

2 pompe centrifughe multistadio a velocità variabile - pressione costante
 2 multistage centrifugal pumps with variable speed - constant pressure
 2 bombas centrifugas multicelulares con velocidad variable - presión constante

28 m³/h +90° 0° °C °C 50 h



Immagine indicativa con inverter tipo "C"
 Indicative image with "C" type inverter
 Imagen indicativa con inverter tipo "C"



2 Gruppo con n.2 pompe verticali
 Booster set with n.2 vertical pumps
 Grupo con n.2 bombas verticales

MODELLO / MODEL	PORTATA TOTALE / TOTAL FLOW RATE													
	l/m	33,4	50	66,6	84	100	134	150	184	234	300	366	466	
	m³/h	0	2	3	4	5	6	8	9	11	14	18	22	28
	PREVALENZA TOTALE (mt) / TOTAL HEAD (mt)													
E-DRIVE-2PVM-F-C01	E-DRIVE-2PVT-F-C01	48	41,5	36,5	30*	22								
E-DRIVE-2PVM-F-C02	E-DRIVE-2PVT-F-C02	74,5	64	56,5	46,5*	34								
E-DRIVE-2PVM-F-C03	E-DRIVE-2PVT-F-C03	102,5	88	78	64*	47								
E-DRIVE-2PVM-F-C04	E-DRIVE-2PVT-F-C04	150,5	130	115	95*	69,5								
E-DRIVE-2PVM-F-C05	E-DRIVE-2PVT-F-C05	54,5	48	44	40,5	36*	26,5	21						
E-DRIVE-2PVM-F-C06	E-DRIVE-2PVT-F-C06	66,5	59	55	50,5	45,5*	34	27						
E-DRIVE-2PVM-F-C07	E-DRIVE-2PVT-F-C07	77	68	63	58	52*	38,5	30,5						
E-DRIVE-2PVM-F-C08	E-DRIVE-2PVT-F-C08	89	78,5	73	67	60*	44,5	36						
E-DRIVE-2PVM-F-C09	E-DRIVE-2PVT-F-C09	99,5	87,5	81	74	66*	48,5	38,5						
E-DRIVE-2PVM-F-C10	E-DRIVE-2PVT-F-C10	112,5	83	99,5	92,5	83*	58	41,5						
E-DRIVE-2PVM-F-C11	E-DRIVE-2PVT-F-C11	127	118	111,5	103,5	93*	64	45,5						
E-DRIVE-2PVM-F-C12	E-DRIVE-2PVT-F-C12	144	134,5	128	119	107,5*	76	55,5						
E-DRIVE-2PVM-F-C13	E-DRIVE-2PVT-F-C13	158,5	148	140,5	130,5	118*	83	60						
E-DRIVE-2PVM-F-C14	E-DRIVE-2PVT-F-C14	68,5			61,5	59,5	55	52	46*	32,5				
E-DRIVE-2PVM-F-C15	E-DRIVE-2PVT-F-C15	79,5			70,5	68	62,5	59	51,5*	35,5				
E-DRIVE-2PVM-F-C16	E-DRIVE-2PVT-F-C16	92			84	81,5	76	72,5	64,5*	47				
E-DRIVE-2PVM-F-C17	E-DRIVE-2PVT-F-C17	103			94	91	85	81	72*	66				
E-DRIVE-2PVM-F-C18	E-DRIVE-2PVT-F-C18	113			105,5	102	93,5	89	80,5*	59,5				
E-DRIVE-2PVM-F-C19	E-DRIVE-2PVT-F-C19	127,5			118,5	114,5	105	99,5	90*	66				
E-DRIVE-2PVM-F-C20	E-DRIVE-2PVT-F-C20	142			131,5	126,5	115,5	110	99*	72				
-	E-DRIVE-2PVT-F-C21	159			149,5	144,5	133	127	115*	85,5				
E-DRIVE-2PVM-F-C22	E-DRIVE-2PVT-F-C22	47			43,5	42,5	41,5	39	35,5*	29	14,5			
E-DRIVE-2PVM-F-C23	E-DRIVE-2PVT-F-C23	59,5			56	55	53,5	51	46,5*	39	21			
E-DRIVE-2PVM-F-C24	E-DRIVE-2PVT-F-C24	71			66	65	63	60	54,5*	44,5	23,5			
-	E-DRIVE-2PVT-F-C25	82,5			76	75	72,5	68,5	62*	50	25			
-	E-DRIVE-2PVT-F-C26	91,5			89,5	88,5	86	81,5	74*	64	42			
-	E-DRIVE-2PVT-F-C27	113			111	109,5	107	101,5	92,5*	80,5	53,5			
-	E-DRIVE-2PVT-F-C28	133			130	128,5	125,5	118,5	108*	93,5	61,5			
-	E-DRIVE-2PVT-F-C29	153,5			150,5	149	145,5	138	125,5*	109	61,5			

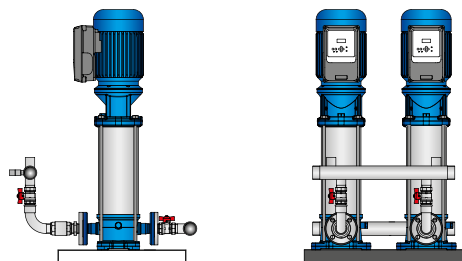
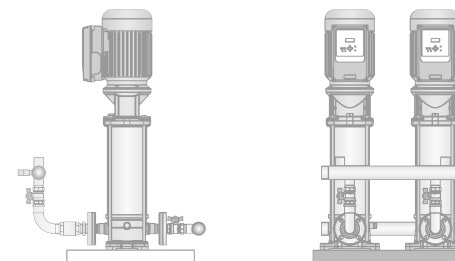
ALIMENTAZIONE / POWER SUPPLY		materiali materials	tipo inverter inverter type	POTENZA / POWER		L mm	W mm	H mm	DN in	DN out	kg
1x230 V~ (50 Hz)	3x400 V~ (50 Hz)			kW	Hp						
E-DRIVE-2PVM-F-C01	E-DRIVE-2PVT-F-C01	●●●	C	2x0,37	2x0,5	790	560	952	1" ½	1" ½	85
E-DRIVE-2PVM-F-C02	E-DRIVE-2PVT-F-C02	●●●	C	2x0,55	2x0,75	790	560	1042	1" ½	1" ½	91
E-DRIVE-2PVM-F-C03	E-DRIVE-2PVT-F-C03	●●●	C	2x0,75	2x1,0	790	560	1148	1" ½	1" ½	99
E-DRIVE-2PVM-F-C04	E-DRIVE-2PVT-F-C04	●●●	C	2x1,1	2x1,5	790	560	1305	1" ½	1" ½	111
E-DRIVE-2PVM-F-C05	E-DRIVE-2PVT-F-C05	●●●	C	2x0,75	2x1,0	680	560	824	2"	2"	89
E-DRIVE-2PVM-F-C06	E-DRIVE-2PVT-F-C06	●●●	C	2x1,1	2x1,5	680	560	848	2"	2"	91
E-DRIVE-2PVM-F-C07	E-DRIVE-2PVT-F-C07	●●●	C	2x1,1	2x1,5	680	560	872	2"	2"	93
E-DRIVE-2PVM-F-C08	E-DRIVE-2PVT-F-C08	●●●	C	2x1,5	2x2,0	680	560	938	2"	2"	101
E-DRIVE-2PVM-F-C09	E-DRIVE-2PVT-F-C09	●●●	C	2x1,5	2x2,0	680	560	962	2"	2"	101
E-DRIVE-2PVM-F-C10	E-DRIVE-2PVT-F-C10	●●●	C	2x1,5	2x2,0	790	560	1193	1" ½	1" ½	111
E-DRIVE-2PVM-F-C11	E-DRIVE-2PVT-F-C11	●●●	C	2x1,5	2x2,0	790	560	1238	1" ½	1" ½	111
E-DRIVE-2PVM-F-C12	E-DRIVE-2PVT-F-C12	●●●	C	2x2,2	2x3,0	790	560	1283	1" ½	1" ½	117
E-DRIVE-2PVM-F-C13	E-DRIVE-2PVT-F-C13	●●●	C	2x2,2	2x3,0	790	560	1328	1" ½	1" ½	119
E-DRIVE-2PVM-F-C14	E-DRIVE-2PVT-F-C14	●●●	C	2x1,5	2x2,0	680	560	890	2"	2"	97
E-DRIVE-2PVM-F-C15	E-DRIVE-2PVT-F-C15	●●●	C	2x1,5	2x2,0	680	560	914	2"	2"	99
E-DRIVE-2PVM-F-C16	E-DRIVE-2PVT-F-C16	●●●	C	2x2,2	2x3,0	680	560	977	2"	2"	107
E-DRIVE-2PVM-F-C17	E-DRIVE-2PVT-F-C17	●●●	C	2x2,2	2x3,0	680	560	1001	2"	2"	113
E-DRIVE-2PVM-F-C18	E-DRIVE-2PVT-F-C18	●●●	C	2x2,2	2x3,0	870	560	1245	2"	2"	117
E-DRIVE-2PVM-F-C19	E-DRIVE-2PVT-F-C19	●●●	C	2x2,2	2x3,0	870	560	1297	2"	2"	119
E-DRIVE-2PVM-F-C20	E-DRIVE-2PVT-F-C20	●●●	C	2x2,2	2x3,0	870	560	1349	2"	2"	121
-	E-DRIVE-2PVT-F-C21	●●●	C	2x3,0	2x4,0	870	560	1450	2"	2"	137
E-DRIVE-2PVM-F-C22	E-DRIVE-2PVT-F-C22	●●●	C	2x1,5	2x2,0	920	560	896	2" ½	2" ½	103
E-DRIVE-2PVM-F-C23	E-DRIVE-2PVT-F-C23	●●●	C	2x2,2	2x3,0	920	560	965	2" ½	2" ½	115
E-DRIVE-2PVM-F-C24	E-DRIVE-2PVT-F-C24	●●●	C	2x2,2	2x3,0	920	560	995	2" ½	2" ½	117
-	E-DRIVE-2PVT-F-C25	●●●	C	2x3,0	2x4,0	920	560	1063	2" ½	2" ½	125
-	E-DRIVE-2PVT-F-C26	●●●	C	2x3,0	2x4,0	930	620	1187	2" ½	2" ½	129
-	E-DRIVE-2PVT-F-C27	●●●	C	2x4,0	2x5,5	930	620	1247	2" ½	2" ½	139
-	E-DRIVE-2PVT-F-C28	●●●	C	2x4,0	2x5,5	930	620	1307	2" ½	2" ½	141
-	E-DRIVE-2PVT-F-C29	●●●	C	2x5,5	2x7,5	930	620	1564	2" ½	2" ½	199

E-DRIVE

2 pompe centrifughe multistadio a velocità variabile - pressione costante
 2 multistage centrifugal pumps with variable speed - constant pressure
 2 bombas centrifugas multicelulares con velocidad variable - presión constante

72
m³/h

+60°
0°
°C

°C

50
H



Immagine indicativa con inverter tipo "V"
 Indicative image with "V" type inverter
 Imagen indicativa con inverter tipo "V"



2 Gruppo con n.2 pompe verticali
 Booster set with n.2 vertical pumps
 Grupo con n.2 bombas verticales

MODELLO / MODEL		PORTATA TOTALE / TOTAL FLOW RATE														
		l/m	0	200	300	400	500	600	700	800	900	1000	1100	1200	1300	1500
		m³/h	0	12	18	24	30	36	42	48	54	60	66	72	78	90
		PREVALENZA TOTALE (mt) / TOTAL HEAD (mt)														
E-DRIVE-2PVM-R-C30	E-DRIVE-2PVT-R-C30	38,6	36	33	29*	22	14									
E-DRIVE-2PVM-R-C31	E-DRIVE-2PVT-R-C31	59	58	56	50*	40	26									
-	E-DRIVE-2PVT-R-C32	79	76	73	67*	54	35									
-	E-DRIVE-2PVT-R-C33	99	97	94	85*	66	46									
-	E-DRIVE-2PVT-R-C34	129	126	121	110*	84	58									
-	E-DRIVE-2PVT-R-C35	149	146	140	126*	100	68									
E-DRIVE-2PVM-R-C36	E-DRIVE-2PVT-R-C36	43,3	41	37	35	33	29*	24	17,3							
-	E-DRIVE-2PVT-R-C37	65	62	55	52	50	44*	36	26							
-	E-DRIVE-2PVT-R-C38	88	83,5	75	72	67	58*	46	34							
-	E-DRIVE-2PVT-R-C39	120	115	104	99	95	82*	66	48							
-	E-DRIVE-2PVT-R-V40	150	134	127	121	116	102*	82	59							
-	E-DRIVE-2PVT-R-C41	45	43	40	38	36	34	31	30*	27	23	17,5	10,6			
-	E-DRIVE-2PVT-R-C42	56,4	56	53	49	45	41	39	37*	35	28	21,9	13,3			
-	E-DRIVE-2PVT-R-C43	90,3	88	82	76	70	64	62	60*	55	45	34,5	21,4			
-	E-DRIVE-2PVT-R-V44	110	106	102	94	86	78	75	73*	66	56	44,4	29,4			

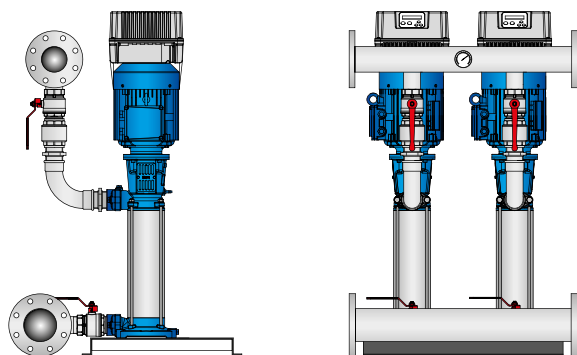
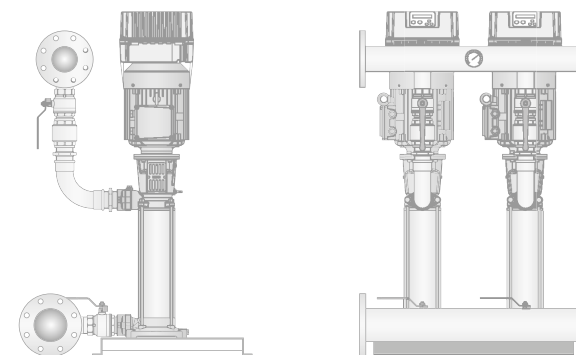
ALIMENTAZIONE / POWER SUPPLY		materiali materials	tipo inverter inverter type	POTENZA / POWER		L mm	W mm	H mm	DN in	DN out	kg
1x230 V~ (50 Hz)	3x400 V~ (50 Hz)			kW	Hp						
E-DRIVE-2PVM-R-C30	E-DRIVE-2PVT-R-C30	●●	C	2x1,5	2x2	830	700	1150	3"	2" ½	124
E-DRIVE-2PVM-R-C31	E-DRIVE-2PVT-R-C31	●●	C	2x2,2	2x3	830	700	1225	3"	2" ½	130
-	E-DRIVE-2PVT-R-C32	●●	C	2x3	2x4	830	700	1330	3"	2" ½	134
-	E-DRIVE-2PVT-R-C33	●●	C	2x4	2x5,5	830	700	1340	3"	2" ½	151
-	E-DRIVE-2PVT-R-C34	●●	C	2x5,5	2x7,5	830	700	1500	3"	2" ½	171
-	E-DRIVE-2PVT-R-C35	●●	C	2x7,5	2x10	830	700	1580	3"	2" ½	184
E-DRIVE-2PVM-R-C36	E-DRIVE-2PVT-R-C36	●●	C	2x2,2	2x3	830	700	1100	3"	2" ½	131
-	E-DRIVE-2PVT-R-C37	●●	C	2x3	2x4	830	700	1190	3"	2" ½	134
-	E-DRIVE-2PVT-R-C38	●●	C	2x4	2x5,5	830	700	1280	3"	2" ½	146
-	E-DRIVE-2PVT-R-C39	●●	C	2x5,5	2x7,5	830	700	1420	3"	2" ½	171
-	E-DRIVE-2PVT-R-V40	●●	V	2x7,5	2x10	830	700	1550	3"	2" ½	176
-	E-DRIVE-2PVT-R-C41	●●	C	2x3	2x4	830	800	1300	DN100	DN80	141
-	E-DRIVE-2PVT-R-C42	●●	C	2x4	2x5,5	830	800	1350	DN100	DN80	154
-	E-DRIVE-2PVT-R-C43	●●	C	2x5,5	2x7,5	830	800	1490	DN100	DN80	176
-	E-DRIVE-2PVT-R-V44	●●	V	2x7,5	2x10	830	800	1590	DN100	DN80	191

E-DRIVE

2 pompe centrifughe multistadio a velocità variabile - pressione costante
 2 multistage centrifugal pumps with variable speed - constant pressure
 2 bombas centrifugas multicelulares con velocidad variable - presión constante

236 $\frac{m^3}{h}$ $+100^{\circ}C$ $0^{\circ}C$ 50 $\frac{m}{h}$



Immagine indicativa con inverter tipo "V"
 Indicative image with "V" type inverter
 Imagen indicativa con inverter tipo "V"

2 Gruppo con n.2 pompe verticali
 Booster set with n.2 vertical pumps
 Grupo con n.2 bombas verticales

MODELLO / MODEL	PORTATA TOTALE / TOTAL FLOW RATE															
	l/m	0	200	300	400	500	600	700	800	900	1000	1100	1200	1300	1500	
	m³/h	0	12	18	24	30	36	42	48	54	60	66	72	78	90	
PREVALENZA TOTALE (mt) / TOTAL HEAD (mt)																
E-DRIVE-2PVT-F-C45	48,5							42,5	41	40	38	36,5	34	32*	30	23,5
E-DRIVE-2PVT-F-V46	73							63,5	61	61	57	55	51	47*	44	35,5
E-DRIVE-2PVT-F-V47	98							86	83	81	78	75	70	65*	60	49,5
E-DRIVE-2PVT-F-V48	122,5							107	103,5	100	96	93,5	87	80*	75	61,5
E-DRIVE-2PVT-F-V49	146,5							128	123,5	120	115	111,5	113	98*	89	73
E-DRIVE-2PVT-F-V50	158							139	133,5	130	126	119	109	103*	92	72,5

MODELLO / MODEL	PORTATA TOTALE / TOTAL FLOW RATE													
	l/m	0	1166	1334	1500	1800	2000	2166	2400	2600	2834	3200	3600	3934
	m³/h	0	70	80	90	108	120	130	144	156	170	192	216	236
PREVALENZA TOTALE (mt) / TOTAL HEAD (mt)														
E-DRIVE-2PVT-F-V51	48,5	43	41,5	39	34*	30,5	26,5							
E-DRIVE-2PVT-F-V52	73,5	65,5	63	60	52,5*	47	41							
E-DRIVE-2PVT-F-V53	97,5	86,5	84	79,5	69,5*	62	54,5							
E-DRIVE-2PVT-F-V54	122	108	104,5	99	86,5*	77	67,5							
E-DRIVE-2PVT-F-V55	147,5	131,5	127	121	106*	95	83,5							
E-DRIVE-2PVT-F-V56	56,5			48	46	45	43	41*	38,5	34,5				
E-DRIVE-2PVT-F-V57	84,5		71,5	69	67	64	61,5*	57,5	51,5					
E-DRIVE-2PVT-F-V58	113,5		96,5	92,5	90,5	86	83*	78	70					
E-DRIVE-2PVT-F-V59	142		121	116,5	114	112	105*	98,5	88,5					
E-DRIVE-2PVT-F-V60	153		133	127,5	123	120	110*	102	89,5					
E-DRIVE-2PVT-F-V61	44,5					41	40	38,5*	36,5	34	28,5*	21,5	15	
E-DRIVE-2PVT-F-V62	62					51,5	50	49	47,5	45	41*	35	28,5	
E-DRIVE-2PVT-F-V63	93,5					78	76	74	72	69	62,5*	53,5	44	
E-DRIVE-2PVT-F-V64	125,5					105	103	99,5	96,5	92,5	84*	72	60	
E-DRIVE-2PVT-F-V65	156					130,5	127	125	123,5	114,5	104,5*	89	74	

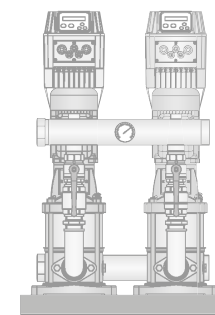
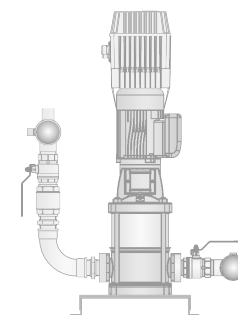
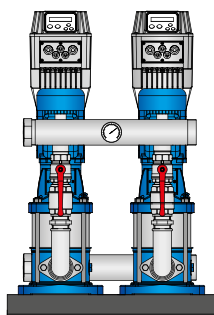
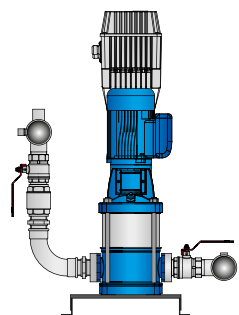
ALIMENTAZIONE / POWER SUPPLY	materiali materials	tipo inverter inverter type	POTENZA / POWER		L mm	W mm	H mm	DN in	DN out	kg
3x400 V - (50 Hz)			kW	Hp						
E-DRIVE-2PVT-F-C45	● ●	C	2x5,5	2x7,5	1150	820	1850	DN100	DN100	466
E-DRIVE-2PVT-F-V46	● ●	V	2x7,5	2x10	1150	820	1850	DN100	DN100	496
E-DRIVE-2PVT-F-V47	● ●	V	2x11	2x15	1150	820	1850	DN100	DN100	516
E-DRIVE-2PVT-F-V48	● ●	V	2x15	2x20	1150	820	1960	DN100	DN100	556
E-DRIVE-2PVT-F-V49	● ●	V	2x15	2x20	1150	820	2060	DN100	DN100	596
E-DRIVE-2PVT-F-V50	● ●	V	2x15	2x20	1150	820	2160	DN100	DN100	616

ALIMENTAZIONE / POWER SUPPLY	materiali materials	tipo inverter inverter type	POTENZA / POWER		L mm	W mm	H mm	DN in	DN out	kg
3x400 V - (50 Hz)			kW	Hp						
E-DRIVE-2PVT-F-V51	● ●	V	2x7,5	2x10	1450	900	1820	DN125	DN125	496
E-DRIVE-2PVT-F-V52	● ●	V	2x11	2x15	1450	900	1820	DN125	DN125	516
E-DRIVE-2PVT-F-V53	● ●	V	2x15	2x20	1450	900	1820	DN125	DN125	596
E-DRIVE-2PVT-F-V54	● ●	V	2x18,5	2x25	1450	900	2000	DN125	DN125	630
E-DRIVE-2PVT-F-V55	● ●	V	2x22	2x30	1450	900	2090	DN125	DN125	680
E-DRIVE-2PVT-F-V56	● ●	V	2x11	2x15	1450	900	1820	DN150	DN150	560
E-DRIVE-2PVT-F-V57	● ●	V	2x18,5	2x25	1450	900	1820	DN150	DN150	570
E-DRIVE-2PVT-F-V58	● ●	V	2x22	2x30	1450	900	1990	DN150	DN150	590
E-DRIVE-2PVT-F-V59	● ●	V	2x30	2x40	1450	900	2090	DN150	DN150	960
E-DRIVE-2PVT-F-V60	● ●	V	2x30	2x40	1450	900	2190	DN150	DN150	980
E-DRIVE-2PVT-F-V61	● ●	V	2x11	2x15	1640	950	1830	DN200	DN200	580
E-DRIVE-2PVT-F-V62	● ●	V	2x15	2x20	1640	950	1830	DN200	DN200	600
E-DRIVE-2PVT-F-V63	● ●	V	2x22	2x30	1640	950	1950	DN200	DN200	830
E-DRIVE-2PVT-F-V64	● ●	V	2x30	2x40	1640	950	2170	DN200	DN200	1180
E-DRIVE-2PVT-F-V65	● ●	V	2x37	2x50	1640	950	2270	DN200	DN200	1200

E-DRIVE

3 pompe centrifughe multistadio a velocità variabile - pressione costante
 3 multistage centrifugal pumps with variable speed - constant pressure
 3 bombas centrifugas multicelulares con velocidad variable - presión constante

87 m³/h	+40° 0° °C	°C	50 H
-------------------	------------------	----	----------------



Immagine indicativa con inverter tipo "C"
 Indicative image with "C" type inverter
 Imagen indicativa con inductor tipo "C"



3 Gruppo con n.3 pompe orizzontali
 Booster set with n.3 horizontal pumps
 Grupo con n.3 bombas horizontales

MODELLO / MODEL	PORTATA TOTALE / TOTAL FLOW RATE																				
	l/m	0	60	120	180	240	300	360	390	450	510	570	630	690	900	1000	1100	1250	1400	1450	
	m³/h	0	3,6	7,2	10,8	14,4	18	21,6	23,4	27	30,6	34,2	37,8	41,4	54	60	66	75	84	87	
PREVALENZA TOTALE (mt) / TOTAL HEAD (mt)																					
E-DRIVE-3PHM-P-C01	E-DRIVE-3PHT-P-C01	40	34,5	27*	17																
E-DRIVE-3PHM-P-C02	E-DRIVE-3PHT-P-C02	52	44,5	34*	22,5																
E-DRIVE-3PHM-F-C03	E-DRIVE-3PHT-F-C03	55	50	42	31*	16															
E-DRIVE-3PHM-F-C04	E-DRIVE-3PHT-F-C04	67	63	53	40*	21															
E-DRIVE-3PHM-F-C05	E-DRIVE-3PHT-F-C05	78	74	61	45*	24															
E-DRIVE-3PHM-F-C06	E-DRIVE-3PHT-F-C06	90	84	71	54*	30															
E-DRIVE-3PHM-F-C07	E-DRIVE-3PHT-F-C07	101	94	79	58*	33															
E-DRIVE-3PHM-P-C08	E-DRIVE-3PHT-P-C08	35	34,5	31	26	20*	13,5	5													
E-DRIVE-3PHM-P-C09	E-DRIVE-3PHT-P-C09	50	47	42	37	30,5*	22	11	5												
E-DRIVE-3PHM-F-C10	E-DRIVE-3PHT-F-C10	57	55	52	48	42	34*	25	20												
E-DRIVE-3PHM-F-C11	E-DRIVE-3PHT-F-C11	70	66	63	58	52	43*	31	24												
E-DRIVE-3PHM-F-C12	E-DRIVE-3PHT-F-C12	81	77	73	66	58	48*	35	27												
E-DRIVE-3PHM-F-C13	E-DRIVE-3PHT-F-C13	92	87	82	75	66	54*	38	28												
-	E-DRIVE-3PHT-F-C14	104	98	93	86	76	64*	45	34												
E-DRIVE-3PHM-F-C15	E-DRIVE-3PHT-F-C15	35			32	31	30	28	27	25,5	23*	19,5	16	11							
E-DRIVE-3PHM-F-C16	E-DRIVE-3PHT-F-C16	48			44	42	40,5	38,5	37	35	31*	26	23	15							
-	E-DRIVE-3PHT-F-C17	59			54	52	50,5	48	46	43	39*	34	27	20							
-	E-DRIVE-3PHT-F-C18	71			65	62	59,5	56	54	51	45*	39	31	22							
-	E-DRIVE-3PHT-F-C19	84			77	74	72	69	67	64	59,5*	53	40	29							
-	E-DRIVE-3PHT-F-C20	96			89	84	82	78	76	72,5	67*	60	50	32							
-	E-DRIVE-3PHT-F-C21	29							26	25,5	25,5	25	24	23	19*	17,5	14,5	9,5			
-	E-DRIVE-3PHT-F-C22	44							39,5	39	38	37,5	36	34,5	29,5*	26	22	14,5			
-	E-DRIVE-3PHT-F-C23	58,5							53	52	51,5	50,5	49	47	40*	35,5	30	20			
-	E-DRIVE-3PHT-F-C24	73							65,5	64,5	63,5	62,5	60	57,5	49*	43,5	36,5	24			
-	E-DRIVE-3PHT-F-C25	87,5							79,5	78	77	75,5	73	71	61,5*	54	46	31,5			
-	E-DRIVE-3PHT-F-C26	102							92	90,5	89	87,5	85	82	70,5*	62	52,5	36			
-	E-DRIVE-3PHT-F-C27	31									27,5	27	26,5	26	24	22,5	20,5*	16,5	12	10	
-	E-DRIVE-3PHT-F-C28	46,5									41,5	41	40	39,5	36,5	34,5	31,5*	25,5	19	16	
-	E-DRIVE-3PHT-F-C29	62,5									56	55,5	54	53,5	49,5	46,5	42,5*	34,5	26	22	
-	E-DRIVE-3PHT-F-C30	78,5									70,5	69,5	68	67	62	58,5	53,5*	43,5	32,5	28	

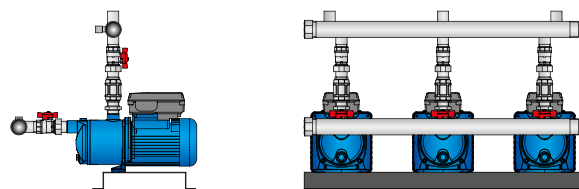
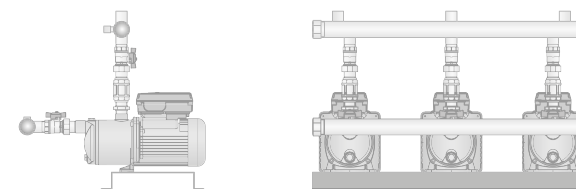
ALIMENTAZIONE / POWER SUPPLY		materiali materials	tipo inverter inverter type	POTENZA / POWER		L mm	W mm	H mm	DN in	DN out	kg
1x230 V~ (50 Hz)	3x400 V~ (50 Hz)			kW	Hp						
E-DRIVE-3PHM-P-C01	E-DRIVE-3PHT-P-C01	●●●	C	3x0,45	3x0,6	1070	820	660	2"	2"	100
E-DRIVE-3PHM-P-C02	E-DRIVE-3PHT-P-C02	●●●	C	3x0,55	3x0,75	1070	820	660	2"	2"	103
E-DRIVE-3PHM-F-C03	E-DRIVE-3PHT-F-C03	●●●	C	3x0,75	3x1	1200	860	660	2"	2"	105
E-DRIVE-3PHM-F-C04	E-DRIVE-3PHT-F-C04	●●●	C	3x1,1	3x1,5	1218	860	660	2"	2"	112
E-DRIVE-3PHM-F-C05	E-DRIVE-3PHT-F-C05	●●●	C	3x1,1	3x1,5	1240	860	660	2"	2"	117
E-DRIVE-3PHM-F-C06	E-DRIVE-3PHT-F-C06	●●●	C	3x1,5	3x2	1265	860	660	2"	2"	124
E-DRIVE-3PHM-F-C07	E-DRIVE-3PHT-F-C07	●●●	C	3x1,5	3x2	1290	860	660	2"	2"	127
E-DRIVE-3PHM-P-C08	E-DRIVE-3PHT-P-C08	●●●	C	3x0,55	3x0,75	1070	820	660	2"	2"	104
E-DRIVE-3PHM-P-C09	E-DRIVE-3PHT-P-C09	●●●	C	3x0,75	3x1	1070	820	660	2"	2"	112
E-DRIVE-3PHM-F-C10	E-DRIVE-3PHT-F-C10	●●●	C	3x1,1	3x1,5	1200	860	660	2"	2"	111
E-DRIVE-3PHM-F-C11	E-DRIVE-3PHT-F-C11	●●●	C	3x1,5	3x2	1218	860	660	2"	2"	121
E-DRIVE-3PHM-F-C12	E-DRIVE-3PHT-F-C12	●●●	C	3x1,5	3x2	1240	860	660	2"	2"	124
E-DRIVE-3PHM-F-C13	E-DRIVE-3PHT-F-C13	●●●	C	3x2,2	3x3	1265	860	660	2"	2"	126
-	E-DRIVE-3PHT-F-C14	●●●	C	3x2,2	3x3	1290	860	660	2"	2"	127
E-DRIVE-3PHM-F-C15	E-DRIVE-3PHT-F-C15	●●●	C	3x1,1	3x1,5	1230	860	660	2" ½	2" ½	102
E-DRIVE-3PHM-F-C16	E-DRIVE-3PHT-F-C16	●●●	C	3x1,5	3x2	1260	860	660	2" ½	2" ½	112
-	E-DRIVE-3PHT-F-C17	●●●	C	3x2,2	3x3	1290	860	660	2" ½	2" ½	115
-	E-DRIVE-3PHT-F-C18	●●●	C	3x2,2	3x3	1320	860	660	2" ½	2" ½	117
-	E-DRIVE-3PHT-F-C19	●●●	C	3x3	3x4	1285	860	660	2" ½	2" ½	142
-	E-DRIVE-3PHT-F-C20	●●●	C	3x3	3x4	1315	860	660	2" ½	2" ½	142
-	E-DRIVE-3PHT-F-C21	●●●	C	3x1,5	3x2	1390	1060	720	3"	2" ½	144
-	E-DRIVE-3PHT-F-C22	●●●	C	3x2,2	3x3	1390	1060	720	3"	2" ½	164
-	E-DRIVE-3PHT-F-C23	●●●	C	3x3	3x4	1440	1060	720	3"	2" ½	169
-	E-DRIVE-3PHT-F-C24	●●●	C	3x4	3x5,5	1560	1060	720	3"	2" ½	214
-	E-DRIVE-3PHT-F-C25	●●●	C	3x5,5	3x7,5	1560	1060	720	3"	2" ½	244
-	E-DRIVE-3PHT-F-C26	●●●	C	3x5,5	3x7,5	1560	1060	720	3"	2" ½	244
-	E-DRIVE-3PHT-F-C27	●●●	C	3x2,2	3x3	1390	1060	720	3"	2" ½	164
-	E-DRIVE-3PHT-F-C28	●●●	C	3x3	3x4	1390	1060	720	3"	2" ½	169
-	E-DRIVE-3PHT-F-C29	●●●	C	3x4	3x5,5	1560	1060	720	3"	2" ½	209
-	E-DRIVE-3PHT-F-C30	●●●	C	3x5,5	3x7,5	1560	1060	720	3"	2" ½	244

E-DRIVE

3 pompe centrifughe multistadio a velocità variabile - pressione costante
 3 multistage centrifugal pumps with variable speed - constant pressure
 3 bombas centrifugas multicelulares con velocidad variable - presión constante

42 m³/h +90° 0° °C °C 50 H



Immagine indicativa con inverter tipo "C"
 Indicative image with "C" type inverter
 Imagen indicativa con inverter tipo "C"



3 Gruppo con n.3 pompe verticali
 Booster set with n.3 vertical pumps
 Grupo con n.3 bombas verticales

MODELLO / MODEL	PORTATA TOTALE / TOTAL FLOW RATE													
	l/m	0	50	75	100	125	150	200	225	275	350	450	550	700
	m³/h	0	3	4,5	6	7,5	9	12	13,5	16,5	21	27	33	42
PREVALENZA TOTALE (mt) / TOTAL HEAD (mt)														
E-DRIVE-3PVM-F-C01	E-DRIVE-3PVT-F-C01	48	41,5	36,5	30*	22								
E-DRIVE-3PVM-F-C02	E-DRIVE-3PVT-F-C02	74,5	64	56,5	46,5*	34								
E-DRIVE-3PVM-F-C03	E-DRIVE-3PVT-F-C03	102,5	88	78	64*	47								
E-DRIVE-3PVM-F-C04	E-DRIVE-3PVT-F-C04	150,5	130	115	95*	69,5								
E-DRIVE-3PVM-F-C05	E-DRIVE-3PVT-F-C05	54,5	48	44	40,5	36*	26,5	21						
E-DRIVE-3PVM-F-C06	E-DRIVE-3PVT-F-C06	66,5	59	55	50,5	45,5*	34	27						
E-DRIVE-3PVM-F-C07	E-DRIVE-3PVT-F-C07	77	68	63	58	52*	38,5	30,5						
E-DRIVE-3PVM-F-C08	E-DRIVE-3PVT-F-C08	89	78,5	73	67	60*	44,5	36						
E-DRIVE-3PVM-F-C09	E-DRIVE-3PVT-F-C09	99,5	87,5	81	74	66*	48,5	38,5						
E-DRIVE-3PVM-F-C10	E-DRIVE-3PVT-F-C10	112,5	83	99,5	92,5	83*	58	41,5						
E-DRIVE-3PVM-F-C11	E-DRIVE-3PVT-F-C11	127	118	111,5	103,5	93*	64	45,5						
E-DRIVE-3PVM-F-C12	E-DRIVE-3PVT-F-C12	144	134,5	128	119	107,5*	76	55,5						
E-DRIVE-3PVM-F-C13	E-DRIVE-3PVT-F-C13	158,5	148	140,5	130,5	118*	83	60						
E-DRIVE-3PVM-F-C14	E-DRIVE-3PVT-F-C14	68,5				61,5	59,5	55	52	46*	32,5			
E-DRIVE-3PVM-F-C15	E-DRIVE-3PVT-F-C15	79,5				70,5	68	62,5	59	51,5*	35,5			
E-DRIVE-3PVM-F-C16	E-DRIVE-3PVT-F-C16	92				84	81,5	76	72,5	64,5*	47			
E-DRIVE-3PVM-F-C17	E-DRIVE-3PVT-F-C17	103				94	91	85	81	72*	66			
E-DRIVE-3PVM-F-C18	E-DRIVE-3PVT-F-C18	113				105,5	102	93,5	89	80,5*	59,5			
E-DRIVE-3PVM-F-C19	E-DRIVE-3PVT-F-C19	127,5				118,5	114,5	105	99,5	90*	66			
E-DRIVE-3PVM-F-C20	E-DRIVE-3PVT-F-C20	142				131,5	126,5	115,5	110	99*	72			
-	E-DRIVE-3PVT-F-C21	159				149,5	144,5	133	127	115*	85,5			
E-DRIVE-3PVM-F-C22	E-DRIVE-3PVT-F-C22	47				43,5	42,5	41,5	39	35,5*	29	14,5		
E-DRIVE-3PVM-F-C23	E-DRIVE-3PVT-F-C23	59,5				56	55	53,5	51	46,5*	39	21		
E-DRIVE-3PVM-F-C24	E-DRIVE-3PVT-F-C24	71				66	65	63	60	54,5*	44,5	23,5		
-	E-DRIVE-3PVT-F-C25	82,5				76	75	72,5	68,5	62*	50	25		
-	E-DRIVE-3PVT-F-C26	91,5				89,5	88,5	86	81,5	74*	64	42		
-	E-DRIVE-3PVT-F-C27	113				111	109,5	107	101,5	92,5*	80,5	53,5		
-	E-DRIVE-3PVT-F-C28	133				130	128,5	125,5	118,5	108*	93,5	61,5		
-	E-DRIVE-3PVT-F-C29	153,5				150,5	149	145,5	138	125,5*	109	61,5		

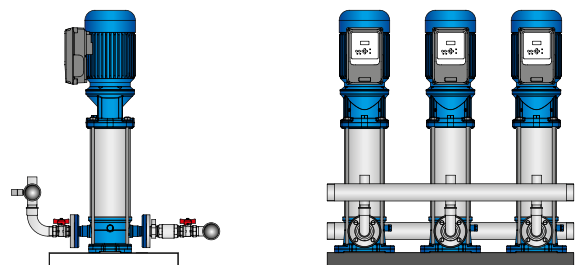
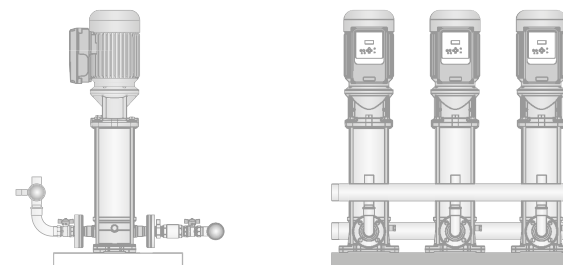
ALIMENTAZIONE / POWER SUPPLY		materiali materials	tipo inverter inverter type	POTENZA / POWER		L mm	W mm	H mm	DN in	DN out	kg
1x230 V~ (50 Hz)	3x400 V~ (50 Hz)			kW	Hp						
E-DRIVE-3PVM-F-C01	E-DRIVE-3PVT-F-C01	●●●	C	3x0,37	3x0,5	830	860	1000	2"	2"	100
E-DRIVE-3PVM-F-C02	E-DRIVE-3PVT-F-C02	●●●	C	3x0,55	3x0,75	830	860	1100	2"	2"	109
E-DRIVE-3PVM-F-C03	E-DRIVE-3PVT-F-C03	●●●	C	3x0,75	3x1,0	830	860	1200	2"	2"	121
E-DRIVE-3PVM-F-C04	E-DRIVE-3PVT-F-C04	●●●	C	3x1,1	3x1,5	830	860	1350	2"	2"	136
E-DRIVE-3PVM-F-C05	E-DRIVE-3PVT-F-C05	●●●	C	3x0,75	3x1,0	870	860	1000	2"	2"	106
E-DRIVE-3PVM-F-C06	E-DRIVE-3PVT-F-C06	●●●	C	3x1,1	3x1,5	870	860	1000	2"	2"	108
E-DRIVE-3PVM-F-C07	E-DRIVE-3PVT-F-C07	●●●	C	3x1,1	3x1,5	870	860	1000	2"	2"	110
E-DRIVE-3PVM-F-C08	E-DRIVE-3PVT-F-C08	●●●	C	3x1,5	3x2,0	870	860	1000	2"	2"	123
E-DRIVE-3PVM-F-C09	E-DRIVE-3PVT-F-C09	●●●	C	3x1,5	3x2,0	870	860	1000	2"	2"	124
E-DRIVE-3PVM-F-C10	E-DRIVE-3PVT-F-C10	●●●	C	3x1,5	3x2,0	830	860	1000	2"	2"	113
E-DRIVE-3PVM-F-C11	E-DRIVE-3PVT-F-C11	●●●	C	3x1,5	3x2,0	830	860	1100	2"	2"	119
E-DRIVE-3PVM-F-C12	E-DRIVE-3PVT-F-C12	●●●	C	3x2,2	3x3,0	830	860	1200	2"	2"	130
E-DRIVE-3PVM-F-C13	E-DRIVE-3PVT-F-C13	●●●	C	3x2,2	3x3,0	830	860	1350	2"	2"	141
E-DRIVE-3PVM-F-C14	E-DRIVE-3PVT-F-C14	●●●	C	3x1,5	3x2,0	870	860	1050	2"	2"	118
E-DRIVE-3PVM-F-C15	E-DRIVE-3PVT-F-C15	●●●	C	3x1,5	3x2,0	870	860	1050	2"	2"	119
E-DRIVE-3PVM-F-C16	E-DRIVE-3PVT-F-C16	●●●	C	3x2,2	3x3,0	870	860	1050	2"	2"	131
E-DRIVE-3PVM-F-C17	E-DRIVE-3PVT-F-C17	●●●	C	3x2,2	3x3,0	870	860	1050	2"	2"	140
E-DRIVE-3PVM-F-C18	E-DRIVE-3PVT-F-C18	●●●	C	3x2,2	3x3,0	950	860	1290	2"	2"	148
E-DRIVE-3PVM-F-C19	E-DRIVE-3PVT-F-C19	●●●	C	3x2,2	3x3,0	950	860	1340	2"	2"	149
E-DRIVE-3PVM-F-C20	E-DRIVE-3PVT-F-C20	●●●	C	3x2,2	3x3,0	950	860	1400	2"	2"	153
-	E-DRIVE-3PVT-F-C21	●●●	C	3x3,0	3x4,0	950	860	1500	2"	2"	178
E-DRIVE-3PVM-F-C22	E-DRIVE-3PVT-F-C22	●●●	C	3x1,5	3x2,0	1000	860	980	2" ½	2" ½	137
E-DRIVE-3PVM-F-C23	E-DRIVE-3PVT-F-C23	●●●	C	3x2,2	3x3,0	1000	860	1010	2" ½	2" ½	145
E-DRIVE-3PVM-F-C24	E-DRIVE-3PVT-F-C24	●●●	C	3x2,2	3x3,0	1000	860	1040	2" ½	2" ½	148
-	E-DRIVE-3PVT-F-C25	●●●	C	3x3,0	3x4,0	1000	860	1110	2" ½	2" ½	160
-	E-DRIVE-3PVT-F-C26	●●●	C	3x3,0	3x4,0	1020	980	1240	2" ½	2" ½	166
-	E-DRIVE-3PVT-F-C27	●●●	C	3x4,0	3x5,5	1020	980	1300	2" ½	2" ½	182
-	E-DRIVE-3PVT-F-C28	●●●	C	3x4,0	3x5,5	1020	980	1360	2" ½	2" ½	187
-	E-DRIVE-3PVT-F-C29	●●●	C	3x5,5	3x7,5	1020	980	1620	2" ½	2" ½	272

E-DRIVE

3 pompe centrifughe multistadio a velocità variabile - pressione costante
 3 multistage centrifugal pumps with variable speed - constant pressure
 3 bombas centrifugas multicelulares con velocidad variable - presión constante

108 m³/h +60°C / 0°C °C °C 50 H



Immagine indicativa con inverter tipo "V"
 Indicative image with "V" type inverter
 Imagen indicativa con inverter tipo "V"



3 Gruppo con n.3 pompe verticali
 Booster set with n.3 vertical pumps
 Grupo con n.3 bombas verticales

MODELLO / MODEL		PORTATA TOTALE / TOTAL FLOW RATE														
		l/m	300	450	600	750	900	1050	1200	1350	1500	1650	1800	1950	2250	
		m³/h	0	18	27	36	45	54	63	72	81	90	99	108	117	135
		PREVALENZA TOTALE (mt) / TOTAL HEAD (mt)														
E-DRIVE-3PVM-R-C30	E-DRIVE-3PVT-R-C30	38,6	36	33	29*	22	14									
E-DRIVE-3PVM-R-C31	E-DRIVE-3PVT-R-C31	59	58	56	50*	40	26									
-	E-DRIVE-3PVT-R-C32	79	76	73	67*	54	35									
-	E-DRIVE-3PVT-R-C33	99	97	94	85*	66	46									
-	E-DRIVE-3PVT-R-C34	129	126	121	110*	84	58									
-	E-DRIVE-3PVT-R-C35	149	146	140	126*	100	68									
E-DRIVE-3PVM-R-C36	E-DRIVE-3PVT-R-C36	43,3	41	37	35	33	29*	24	17,3							
-	E-DRIVE-3PVT-R-C37	65	62	55	52	50	44*	36	26							
-	E-DRIVE-3PVT-R-C38	88	83,5	75	72	67	58*	46	34							
-	E-DRIVE-3PVT-R-C39	120	115	104	99	95	82*	66	48							
-	E-DRIVE-3PVT-R-V40	150	134	127	121	116	102*	82	59							
-	E-DRIVE-3PVT-R-C41	45	43	40	38	36	34	31	30*	27	23	17,5	10,6			
-	E-DRIVE-3PVT-R-C42	56,4	56	53	49	45	41	39	37*	35	28	21,9	13,3			
-	E-DRIVE-3PVT-R-C43	90,3	88	82	76	70	64	62	60*	55	45	34,5	21,4			
-	E-DRIVE-3PVT-R-V44	110	106	102	94	86	78	75	73*	66	56	44,4	29,4			

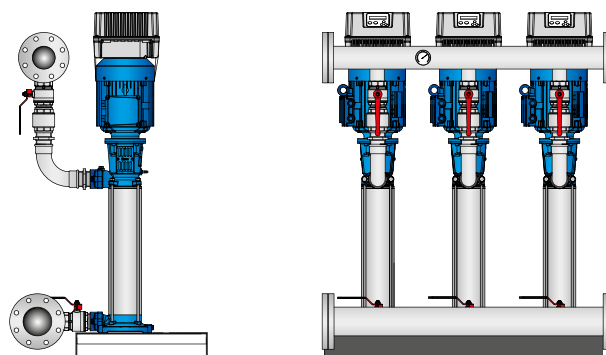
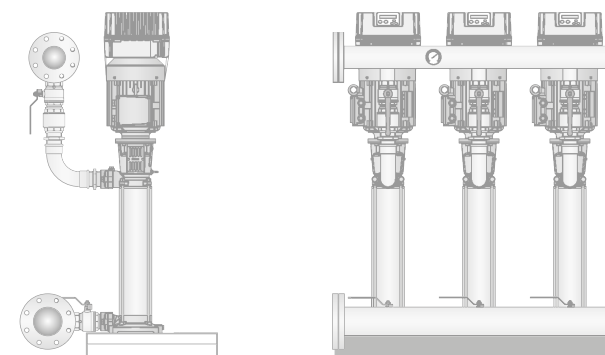
ALIMENTAZIONE / POWER SUPPLY		materiali materials	tipo inverter inverter type	POTENZA / POWER		L W H			DN in DN out		kg
1x230 V~ (50 Hz)	3x400 V~ (50 Hz)			kW	Hp	mm	mm	mm			
E-DRIVE-3PVM-R-C30	E-DRIVE-3PVT-R-C30	●●	C	3x1,5	3x2	755	1110	1560	DN100	DN80	190
E-DRIVE-3PVM-R-C31	E-DRIVE-3PVT-R-C31	●●	C	3x2,2	3x3	755	1110	1560	DN100	DN80	200
-	E-DRIVE-3PVT-R-C32	●●	C	3x3	3x4	755	1110	1560	DN100	DN80	210
-	E-DRIVE-3PVT-R-C33	●●	C	3x4	3x5,5	755	1110	1560	DN100	DN80	230
-	E-DRIVE-3PVT-R-C34	●●	C	3x5,5	3x7,5	755	1110	1560	DN100	DN80	260
-	E-DRIVE-3PVT-R-C35	●●	C	3x7,5	3x10	755	1110	1560	DN100	DN80	280
E-DRIVE-3PVM-R-C36	E-DRIVE-3PVT-R-C36	●●	C	3x2,2	3x3	755	1110	1560	DN100	DN80	200
-	E-DRIVE-3PVT-R-C37	●●	C	3x3	3x4	755	1110	1560	DN100	DN80	210
-	E-DRIVE-3PVT-R-C38	●●	C	3x4	3x5,5	755	1110	1560	DN100	DN80	225
-	E-DRIVE-3PVT-R-C39	●●	C	3x5,5	3x7,5	755	1110	1560	DN100	DN80	260
-	E-DRIVE-3PVT-R-V40	●●	V	3x7,5	3x10	755	1110	1580	DN100	DN80	320
-	E-DRIVE-3PVT-R-C41	●●	C	3x3	3x4	755	1110	1580	DN125	DN100	224
-	E-DRIVE-3PVT-R-C42	●●	C	3x4	3x5,5	755	1110	1580	DN125	DN100	242
-	E-DRIVE-3PVT-R-C43	●●	C	3x5,5	3x7,5	755	1110	1580	DN125	DN100	281
-	E-DRIVE-3PVT-R-V44	●●	V	3x7,5	3x10	755	1110	1580	DN125	DN100	299

E-DRIVE

3 pompe centrifughe multistadio a velocità variabile - pressione costante
 3 multistage centrifugal pumps with variable speed - constant pressure
 3 bombas centrifugas multicelulares con velocidad variable - presión constante

354 m³/h $+100^{\circ}$ 0° °C $^{\circ}$ C 50 H



Immagine indicativa con inverter tipo "V"
 Indicative image with "V" type inverter
 Imagen indicativa con inverter tipo "V"



3 Gruppo con n.3 pompe verticali
 Booster set with n.3 vertical pumps
 Grupo con n.3 bombas verticales

MODELLO / MODEL	PORTATA TOTALE / TOTAL FLOW RATE														
	l/m	0	300	450	600	750	900	1050	1200	1350	1500	1650	1800	1950	2250
	m³/h	0	18	27	36	45	54	63	72	81	90	99	108	117	135
	PREVALENZA TOTALE (mt) / TOTAL HEAD (mt)														
E-DRIVE-3PVT-F-C45	48,5						42,5	41	40	38	36,5	34	32*	30	23,5
E-DRIVE-3PVT-F-V46	73						63,5	61	61	57	55	51	47*	44	35,5
E-DRIVE-3PVT-F-V47	98						86	83	81	78	75	70	65*	60	49,5
E-DRIVE-3PVT-F-V48	122,5						107	103,5	100	96	93,5	87	80*	75	61,5
E-DRIVE-3PVT-F-V49	146,5						128	123,5	120	115	111,5	113	98*	89	73
E-DRIVE-3PVT-F-V50	158						139	133,5	130	126	119	109	103*	92	72,5

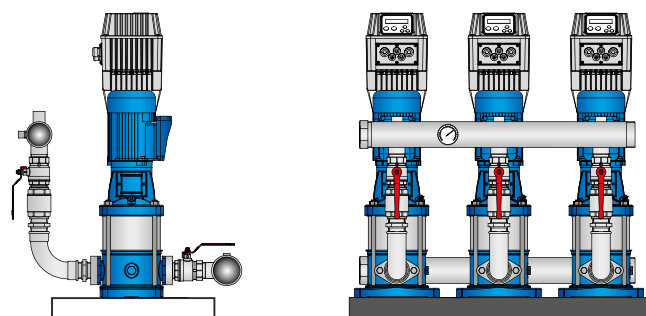
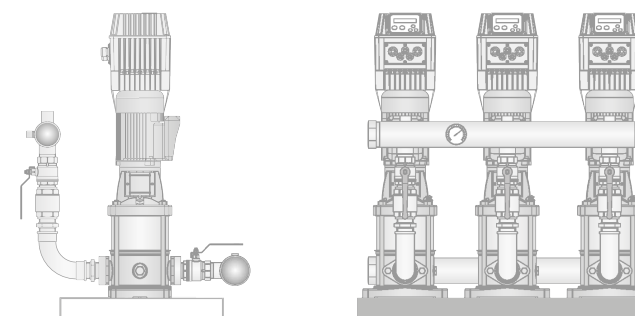
MODELLO / MODEL	PORTATA TOTALE / TOTAL FLOW RATE													
	l/m	0	1750	2000	2250	2700	3000	3250	3600	3900	4250	4800	5400	5900
	m³/h	0	105	120	135	162	180	195	216	234	255	288	324	354
	PREVALENZA TOTALE (mt) / TOTAL HEAD (mt)													
E-DRIVE-3PVT-F-V51	48,5	43	41,5	39	34*	30,5	26,5							
E-DRIVE-3PVT-F-V52	73,5	65,5	63	60	52,5*	47	41							
E-DRIVE-3PVT-F-V53	97,5	86,5	84	79,5	69,5*	62	54,5							
E-DRIVE-3PVT-F-V54	122	108	104,5	99	86,5*	77	67,5							
E-DRIVE-3PVT-F-V55	147,5	131,5	127	121	106*	95	83,5							
E-DRIVE-3PVT-F-V56	56,5			48	46	45	43	41*	38,5	34,5				
E-DRIVE-3PVT-F-V57	84,5			71,5	69	67	64	61,5*	57,5	51,5				
E-DRIVE-3PVT-F-V58	113,5			96,5	92,5	90,5	86	83*	78	70				
E-DRIVE-3PVT-F-V59	142			121	116,5	114	112	105*	98,5	88,5				
E-DRIVE-3PVT-F-V60	153			133	127,5	123	120	110*	102	89,5				
E-DRIVE-3PVT-F-V61	44,5					41	40	38,5*	36,5	34	28,5*	21,5	15	
E-DRIVE-3PVT-F-V62	62					51,5	50	49	47,5	45	41*	35	28,5	
E-DRIVE-3PVT-F-V63	93,5					78	76	74	72	69	62,5*	53,5	44	
E-DRIVE-3PVT-F-V64	125,5					105	103	99,5	96,5	92,5	84*	72	60	
E-DRIVE-3PVT-F-V65	156					130,5	127	125	123,5	114,5	104,5*	89	74	

ALIMENTAZIONE / POWER SUPPLY	materiali materials	tipo inverter inverter type	POTENZA / POWER		L mm	W mm	H mm	DN in	DN out	kg
3x400 V~ (50 Hz)			kW	Hp						
E-DRIVE-3PVT-F-C45	● ●	C	3x5,5	3x7,5	1150	1220	1850	DN125	DN125	728
E-DRIVE-3PVT-F-V46	● ●	V	3x7,5	3x10	1170	1220	1850	DN125	DN125	774
E-DRIVE-3PVT-F-V47	● ●	V	3x11	3x15	1170	1220	1850	DN125	DN125	805
E-DRIVE-3PVT-F-V48	● ●	V	3x15	3x20	1170	1220	1960	DN125	DN125	867
E-DRIVE-3PVT-F-V49	● ●	V	3x15	3x20	1170	1220	2060	DN125	DN125	929
E-DRIVE-3PVT-F-V50	● ●	V	3x15	3x20	1170	1220	2160	DN125	DN125	960

ALIMENTAZIONE / POWER SUPPLY	materiali materials	tipo inverter inverter type	POTENZA / POWER		L mm	W mm	H mm	DN in	DN out	kg
3x400 V~ (50 Hz)			kW	Hp						
E-DRIVE-3PVT-F-V51	● ●	V	3x7,5	3x10	1450	1270	1820	DN150	DN150	774
E-DRIVE-3PVT-F-V52	● ●	V	3x11	3x15	1450	1270	1820	DN150	DN150	805
E-DRIVE-3PVT-F-V53	● ●	V	3x15	3x20	1450	1270	1820	DN150	DN150	929
E-DRIVE-3PVT-F-V54	● ●	V	3x18,5	3x25	1450	1270	2000	DN150	DN150	960
E-DRIVE-3PVT-F-V55	● ●	V	3x22	3x30	1450	1270	2090	DN150	DN150	1038
E-DRIVE-3PVT-F-V56	● ●	V	3x11	3x15	1630	1300	1840	DN200	DN200	852
E-DRIVE-3PVT-F-V57	● ●	V	3x18,5	3x25	1630	1300	1840	DN200	DN200	867
E-DRIVE-3PVT-F-V58	● ●	V	3x22	3x30	1630	1300	2010	DN200	DN200	898
E-DRIVE-3PVT-F-V59	● ●	V	3x30	3x40	1630	1300	2110	DN200	DN200	1472
E-DRIVE-3PVT-F-V60	● ●	V	3x30	3x40	1630	1300	2210	DN200	DN200	1503
E-DRIVE-3PVT-F-V61	● ●	V	3x11	3x15	1700	1400	1850	DN250	DN250	883
E-DRIVE-3PVT-F-V62	● ●	V	3x15	3x20	1700	1400	1850	DN250	DN250	914
E-DRIVE-3PVT-F-V63	● ●	V	3x22	3x30	1700	1400	1970	DN250	DN250	1270
E-DRIVE-3PVT-F-V64	● ●	V	3x30	3x40	1700	1400	1890	DN250	DN250	1813
E-DRIVE-3PVT-F-V65	● ●	V	3x37	3x50	1700	1400	2000	DN250	DN250	1844